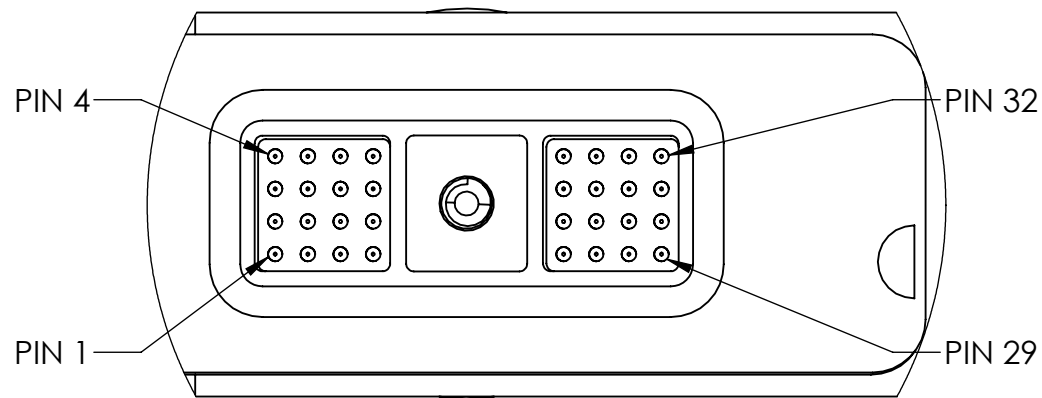
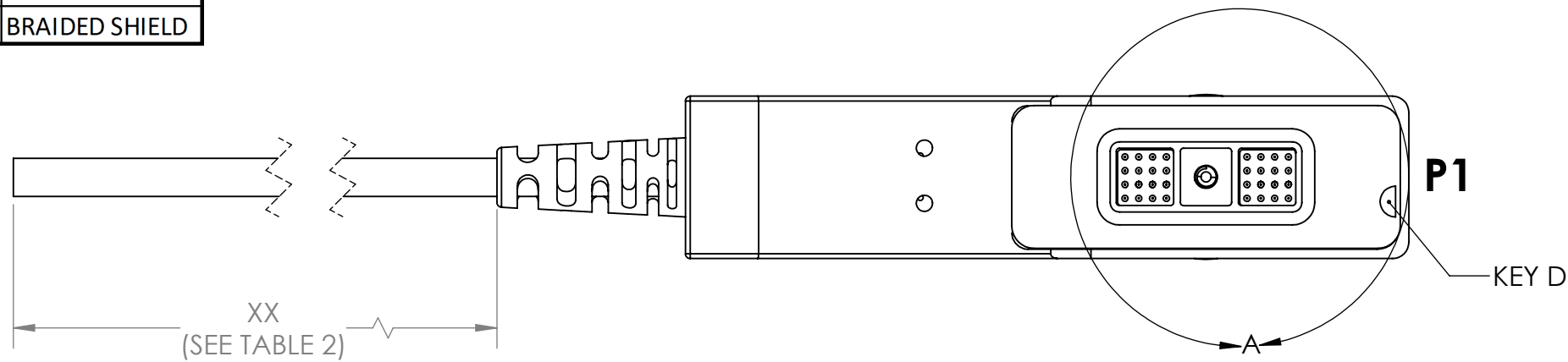

TABLE 1. WIRE RUN LIST	
P1 PIN NUMBER	WIRE COLOR
1	RED
2	YELLOW
3	BROWN
5	WHITE
6	GREEN
8	BLACK
9	LIGHT BLUE
10	DARK ORANGE
22	PINK
23	BLUE
25	VIOLET
27	CLEAR
28	DARK GREEN
29	GRAY
30	LIGHT GREEN
31	TAN
32	DARK BLUE
E33, E34	BRAIDED SHIELD

TWISTED PAIR



DETAIL A
SCALE 2 : 1



REV	DATE	DESCRIPTION OF CHANGE	ENG
A	12/1/16	INITIAL RELEASE	LS

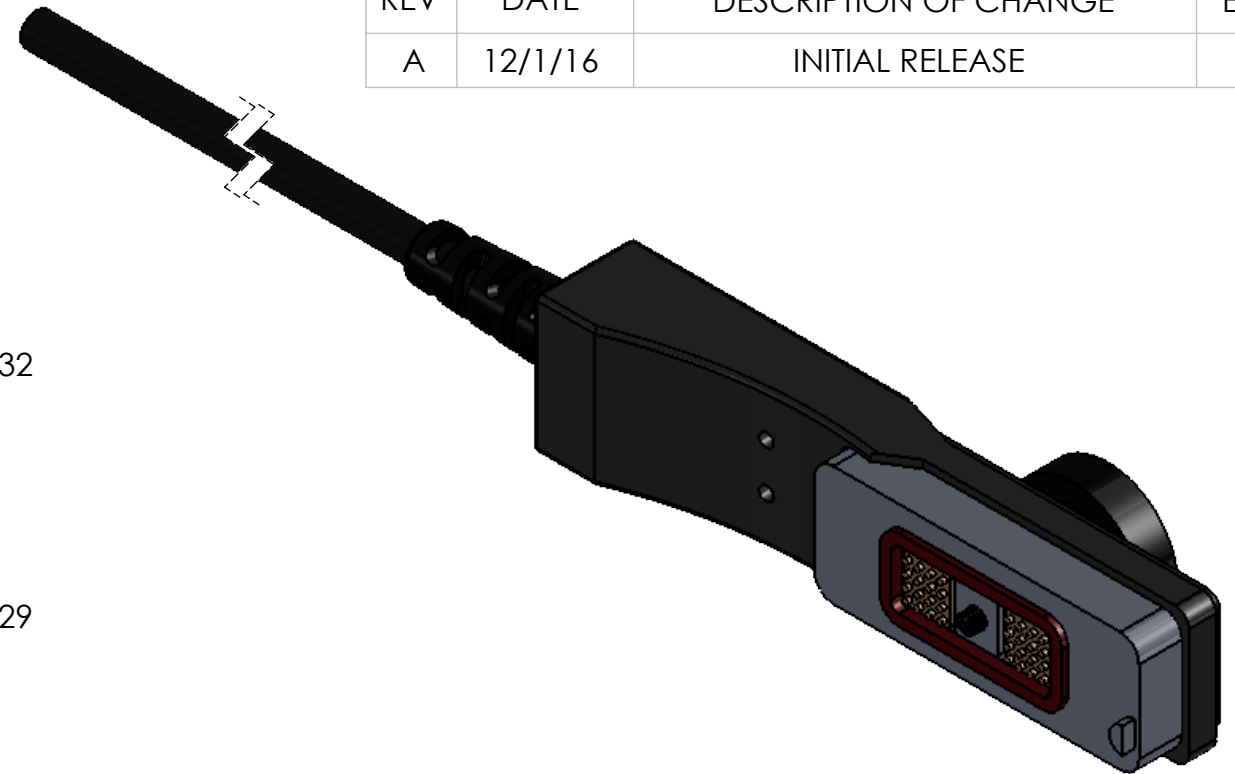

TABLE 2: WIRE LENGTH TABLE	
XX	WIRE LENGTH (INCHES)
03	36.0" ± 1.0"
05	60.0" ± 2.0"
06	72.0" ± 2.0"
08	96.0" ± 2.0"
12	144.0" ± 3.0"
15	180.0" ± 3.0"

BILL OF MATERIALS				
ITEM NO.	PART NUMBER	QTY	NAME	COMMENTS
1	51234	AR	WIRE	19C
2	TE-32D-ASSY	1	CONNECTOR ASSEMBLY	INCLUDES HOUSING, FASTENERS, PCB, THUMBWHEEL. PROVIDED BY SUPPLYNET
3	SN0072	1	PCB	

NOTES:

- CABLE: 26 AWG, 19 CONDUCTOR, OD: 0.270 NOMINAL. POLYURETHANE INSULATION. OUTER SHIELD 38 AWG, TIN PLATED COPPER BRAID, 90% COVERAGE.
- JACKET: BLACK MATTE FINISH.
- E33, E34 IS CHASSIS GROUND
- SOLDERING IAW IPC-J-STD-001 CLASS II AS APPLICABLE.
- CABLE ASSEMBLIES TO BE 100% TESTED FOR CONTINUITY, SHORTS AND INSULATION RESISTANCE (250V @ 100MOHM MINIMUM)
- IDENTIFICATION: BAG AND IDENTIFY ON PACKAGING THE FOLLOWING INFORMATION FOR EACH PART DELIVERED. UOS PART MARKING ON THE WIRE IS PROHIBITED:
PN: TE-32D-C-XX REV X (REV MARKING PER PO)
CAGE CODE: 1HJX9
DATE OF MFG: MM/YY
- WIRING FUNCTION: SEE SHEET 2 TABLE 1 AND DRAWING SN0072.
- REFERENCE SUPPLYNET FILE NUMBER SN0156.
- MANUFACTURE AND INSPECT IAW IPC/WHMA A-620 CLASS 2.

UNLESS OTHERWISE SPECIFIED:
 DIMENSIONS ARE IN: INCHES
 TOLERANCES: .XX: ± 0.03
 .XXX: ± 0.005
 ANGULAR: .X°: 1°
 .XX°: 0.5°
 BREAK EDGES: .005 - .020
 FILLETS: .005 - .020
 SURFACE FINISH:
 GEOMETRIC TOLERANCING PER: ASME Y14.5-2009
 MATERIAL: SEE DRAWING NOTES
 FINISH: SEE DRAWING NOTES
 DO NOT SCALE DRAWING

NAME	DATE
DRAWN: LS	12/1/16
CHECKED: RB	12/1/16
COMMENTS:	
PROPRIETARY AND CONFIDENTIAL THE INFORMATION CONTAINED IN THIS DRAWING IS THE SOLE PROPERTY OF SUPPLYNET, INC. ANY REPRODUCTION IN PART OR AS A WHOLE WITHOUT THE WRITTEN PERMISSION OF SUPPLYNET INC. IS PROHIBITED.	

REF. NUMBER: SN0448

SupplyNet 706 EXECUTIVE BLVD.
SUITE B
VALLEY COTTAGE, NY 10989

TITLE: **RF-7850M 32 PIN DATA CABLE**

SIZE: B	DWG. NO.: TE-32D-C-XX	REV: A
----------------	------------------------------	---------------

SCALE: NA WEIGHT: SHEET 1 OF 1