

REV	DATE	DESCRIPTION OF CHANGE	ENG
A	6/3/20	INITAL REV.	TC

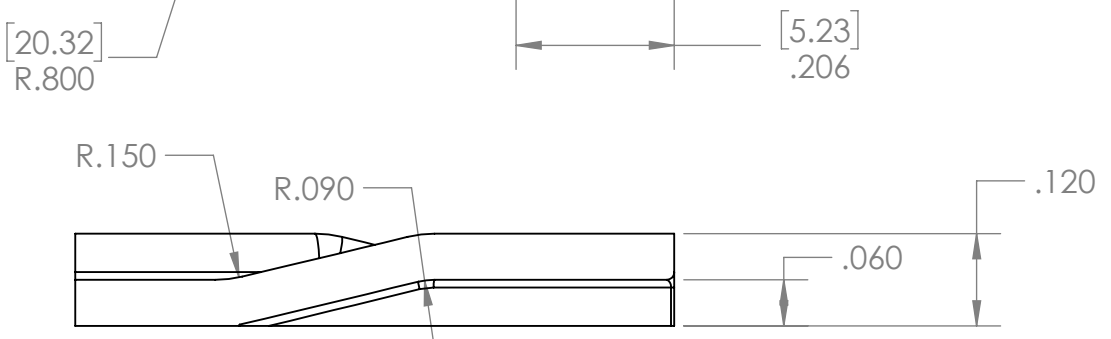
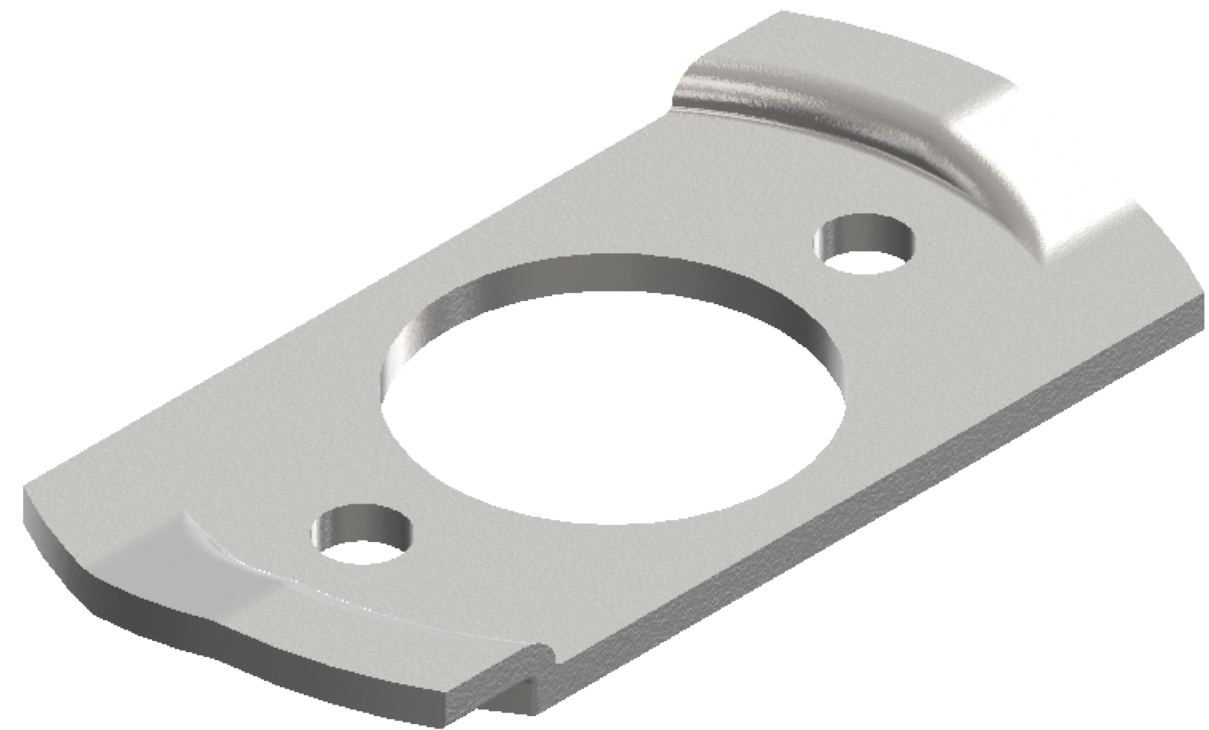
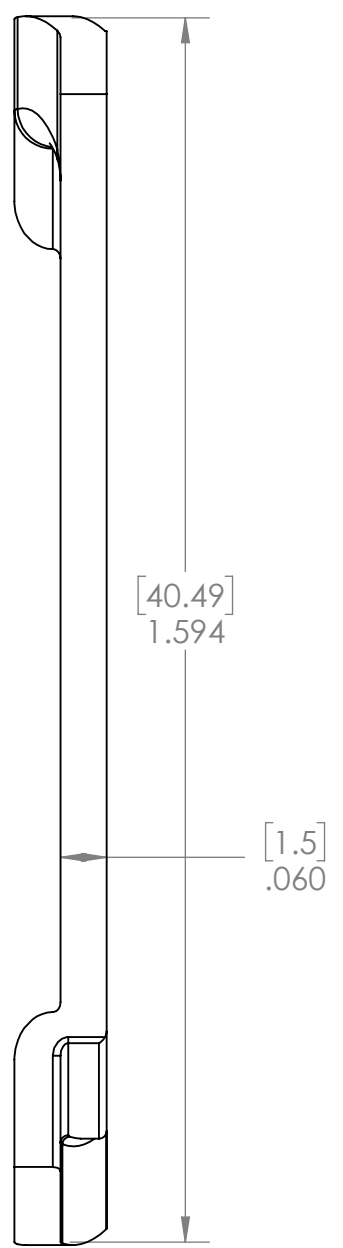
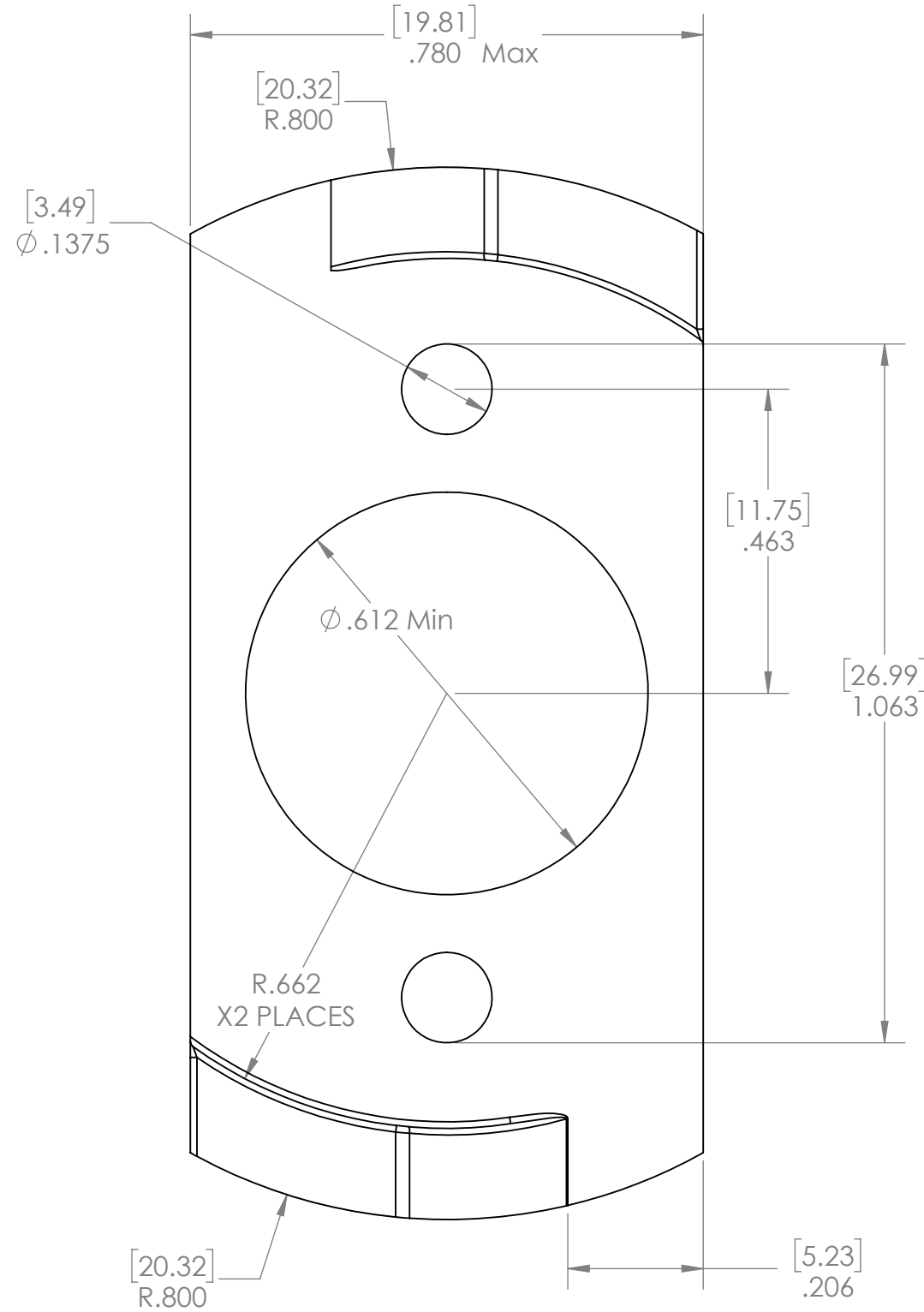

- NOTES:
1. REFER TO 3D CAD FILE 1116-01-106-STAMPED
 2. MATERIAL: STAINLESS STEEL 304
 3. FINISH : POLISH #4
 4. REMOVE ALL SHARP EDGES AND BURS

UNLESS OTHERWISE SPECIFIED:
 DIMENSIONS ARE IN: INCHES
 TOLERANCES: .XX: ± 0.03
 .XXX: ± 0.005
 ANGULAR: .X°:]°
 .XX°: 0.5°
 BREAK EDGES: .005 - .020
 FILLETS: .005 - .020
 SUFACE FINISH:
 GEOMETRIC TOLERANCING
 PER: ASME Y14.5 -2009
 MATERIAL: SEE DRAWING NOTES
 FINISH: SEE DRAWING NOTES
 DO NOT SCALE DRAWING

	NAME	DATE
DRAWN	TC	6/3/20
CHECKED	RJB	6/3/20
COMMENTS:		

REF. NUMBER: SN0436

SupplyNet 706 EXECUTIVE BLVD.
SUITE B
VALLEY COTTAGE, NY 10989

TITLE:
**MBITR STEEL TAB
(STAMPED)**

SIZE	DWG. NO.	REV
B	1116-01-106-STAMPED	A

CAGE CODE: 1HJX9

SCALE: NA WEIGHT: SHEET 1 OF 1