

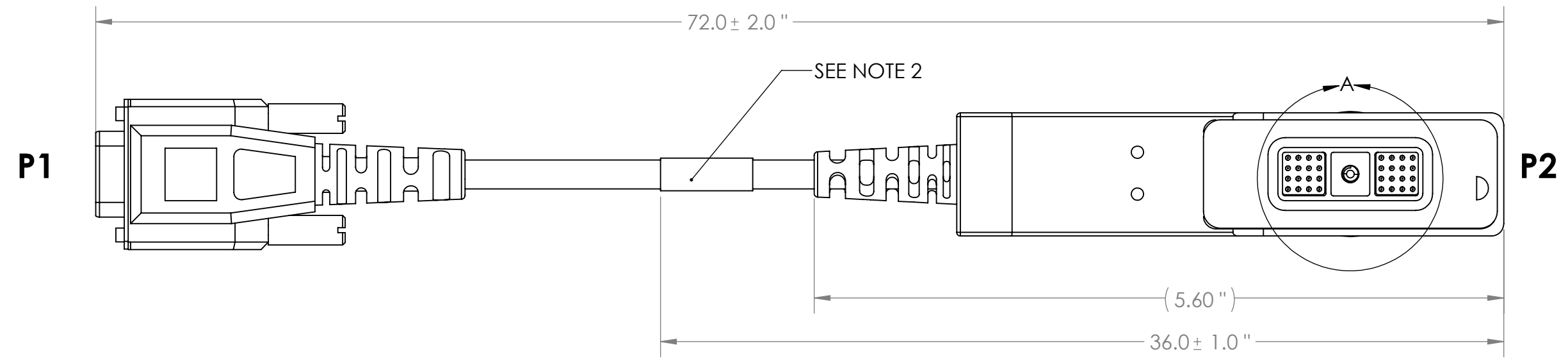

REV	DATE	DESCRIPTION OF CHANGE	ENG
B	04/04/14	REVISED PER DCN SN0139A	RJB

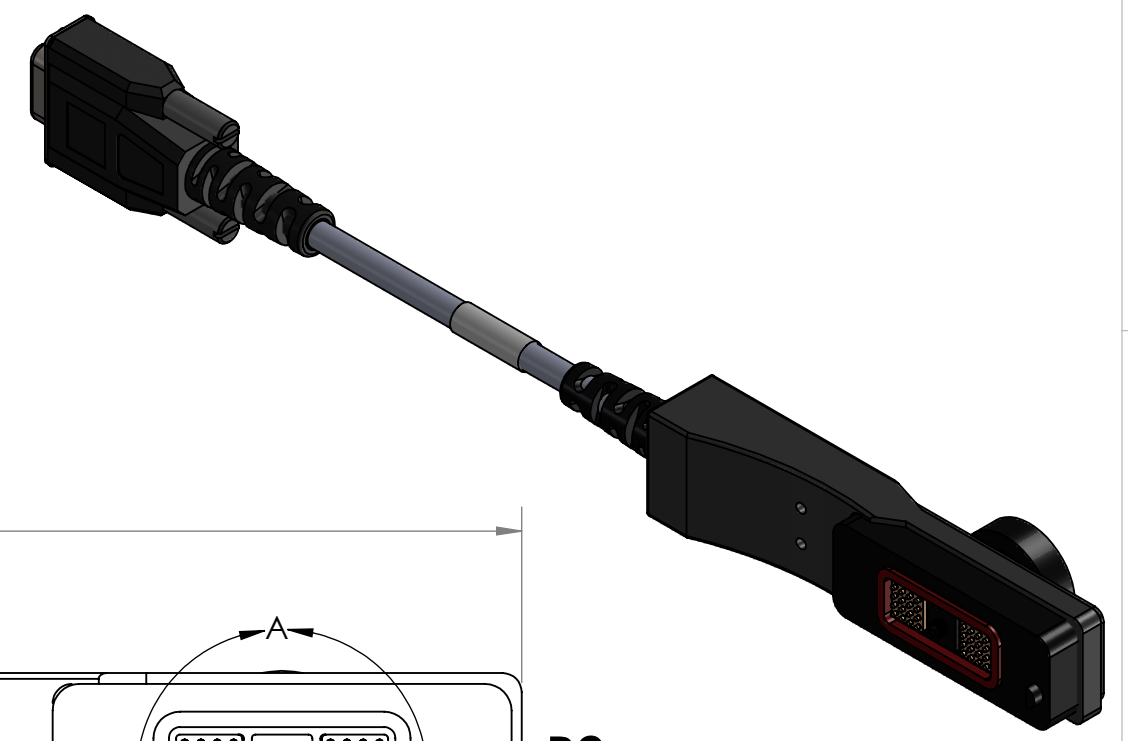
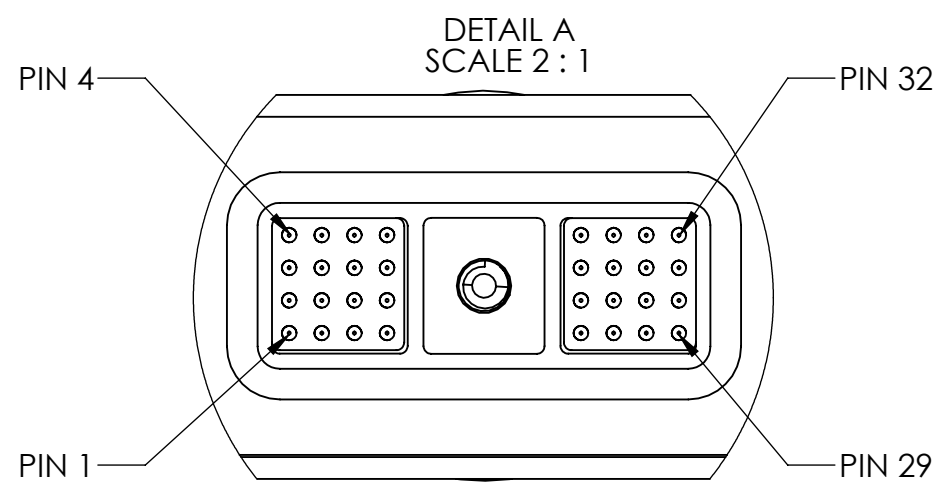

- NOTES:
- 1) WIRE PER TABLE 1.
  - 2) ATTACH ADHESIVE LABEL WITH THE FOLLOWING INFORMATION:  
**PN: SN-840 REV. X (REV MARKING PER PO)**  
**CAGE CODE: 1HJX9**  
**DATE OF MFG: MM/YY**
  - 3) REFERENCE SUPPLYNET FILE NUMBER SN0139.
  - 4) ENCAPSULATE SOLDER JOINTS OF P1 WITH TRV..
  - 5) ATTACH DRAIN WIRE AND SHIELD TO SHELL OF P1.
  - 6) CAP AND STOW UNUSED WIRES.
  - 7) SOLDERING IAW IPC-J-STD-001 CLASS II AS APPICABLE.
  - 8) MANUFACTURE AND INSPECT IAW IPC/WHMA A-620 CLASS 2.
  - 9) SOURCE SUGGESTION. ALTERNATE COMPLIANT SUPPLIERS ACCEPTABLE.

UNLESS OTHERWISE SPECIFIED:	NAME	DATE
DIMENSIONS ARE IN: INCHES	DRAWN	RJB 06/26/13
TOLERANCES: .XX: ± 0.03	CHECKED	RJB 06/26/13
.XXX: ± 0.005	COMMENTS:	
ANGULAR: .X°: 1°	<b>PROPRIETARY AND CONFIDENTIAL</b>	
.XX°: 0.5°	THE INFORMATION CONTAINED IN THIS DRAWING IS THE SOLE PROPERTY OF SUPPLYNET, INC. ANY REPRODUCTION IN PART OR AS A WHOLE WITHOUT THE WRITTEN PERMISSION OF SUPPLYNET INC. IS PROHIBITED.	
BREAK EDGES: .005 - .020	CAGE CODE: 1HJX9	
FILLET: .005 - .020		
SURFACE FINISH:		
GEOMETRIC TOLERANCING PER: ASME Y14.5-2009		
MATERIAL: SEE DRAWING NOTES		
FINISH: SEE DRAWING NOTES		
DO NOT SCALE DRAWING		

PART NUMBER: SN-840		
 706 EXECUTIVE BLVD. SUITE B VALLEY COTTAGE, NY 10989		
TITLE: <b>PRC-152 REMOTE CONTROL DATA CABLE, 6 FEET CROSS REFERENCE # 12041-7110</b>		
SIZE <b>B</b>	DWG. NO. <b>SN-840</b>	REV <b>B</b>
SCALE: NA	WEIGHT:	SHEET 1 OF 1