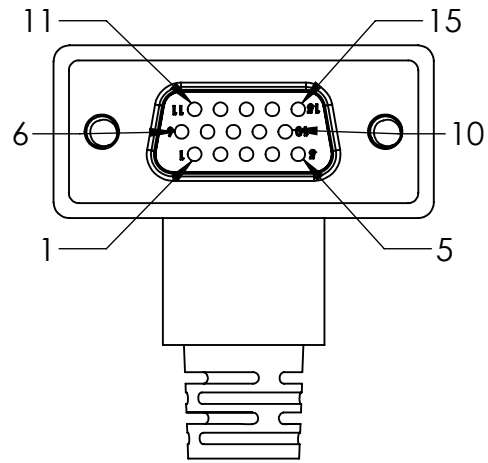

TABLE 1: WIRE RUN		
P1	WIRE COLOR	P2
1	COAX CENTER 1	6
2	COAX SHIELD 1	11
6	COAX CENTER 2	1
11	COAX SHIELD 2	2
14	BLACK	15
15	RED	14
3	N/C	3
13	N/C	13
SHELL	SHIELD	SHELL

TABLE 2: LABEL IDENTIFICATION		
ITEM NO.	LABEL TEXT	NOTES
4	SN-987-5182-001 CAGE: 1HJX9 MFD: MM/YY	SEE NOTE 2. REV. MARKING PER PO.

REVISIONS			
REV.	DESCRIPTION	DATE	ENG
A	INITIAL RELEASE	01/03/2023	MOB

JUMPED



P1 & P2 PINOUT
(MATING FACE VIEW)

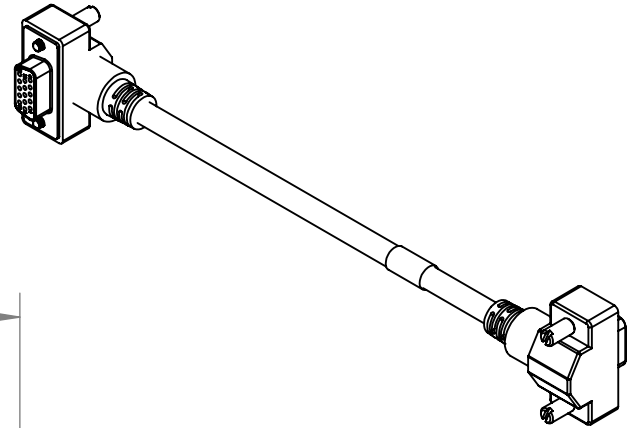
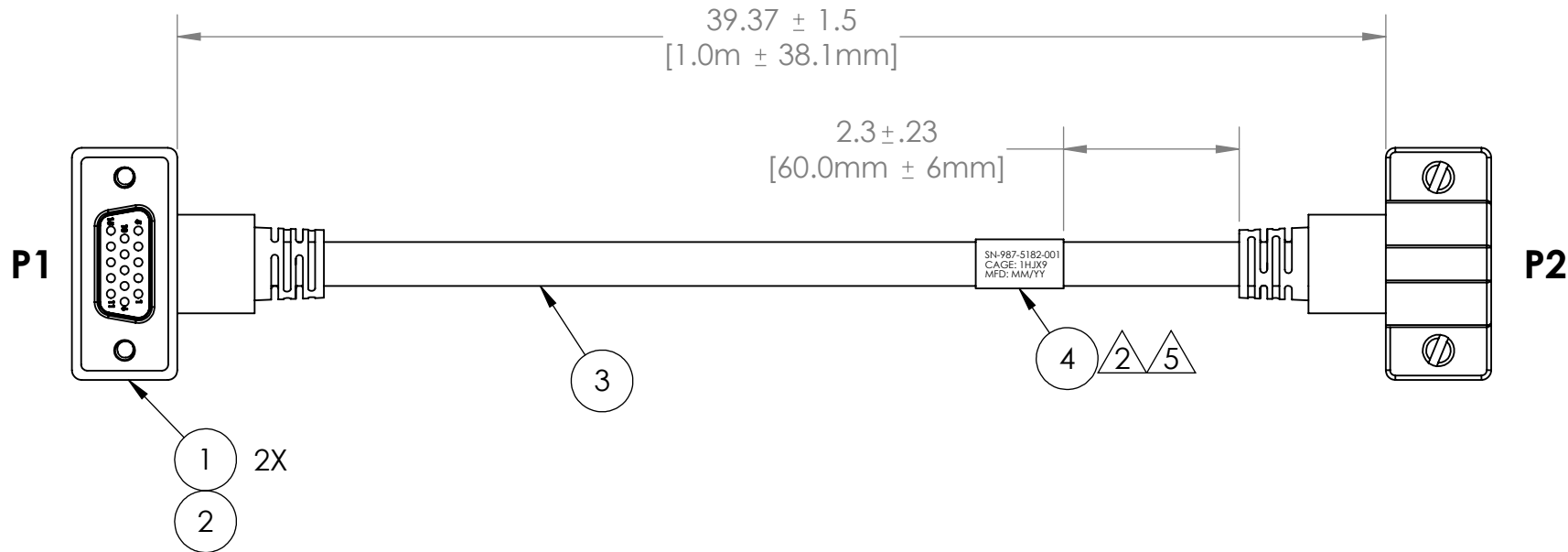

NOTES:

- WIRING SHALL BE DONE IN ACCORDANCE WITH TABLE 1 WIRE RUN LIST.
- MARKING REQUIREMENTS:
 - LABELS SHALL BE MARKED IN ACCORDANCE WITH MIL-STD-130 AS APPLICABLE.
 - LABELS SHALL BE WHITE WITH BLACK TEXT.
 - LABELS SHALL BE PLACED WHERE SHOWN IN DRAWING.
 - ADHESIVE WRAP-AROUND LABEL MAY BE USED.
- SEE TABLE 2 FOR LABEL TEXT
- SOLDERING: IAW IPC-J-STD-001 CLASS 2 AS APPLICABLE
- ASSEMBLY TO BE 100% TESTED FOR SHORTS, CONTINUITY, AND JACKET RESISTANCE (250V @ 100MOHM MIN.)
- PACKAGING REQUIREMENTS:
 - EACH COMPLETED ASSEMBLY SHALL BE PLACED IN A ZIP POLY BAG.
 - EACH POLY BAG SHALL BE LABELED WITH THE BELOW INFORMATION ONLY.
PN: SN-987-5011-001REV. X (REV MARKING PER PO)
CAGE CODE: 1HJX9
MFD: MM/YY
- MANUFACTURE AND INSPECT IAW IPC/WHMA A-620 CLASS 2.

BILL OF MATERIALS			
ITEM NO.	PART NO.	QTY	NAME/DESCRIPTION
1	09HD15	2	HD15, FEMALE, 15 POS.
2	0429-OM-01	2	HD15 OVER-MOLD, BLACK
3	X-2316426PU	40.0"	CABLE: 4C, (2) AWG 26, (2) COAX, SHIELDED, PU JACKET, BLACK.
4	TBD	1.0"	ADHESIVE WRAP-AROUND LABEL

UNLESS OTHERWISE SPECIFIED:
 DIMENSIONS ARE IN: INCHES
 TOLERANCES: .XX: ± 0.03
 .XXX: ± 0.005
 ANGULAR: .X°:]°
 .XX°: 0.5°
 BREAK EDGES: .005 - .020
 FILLETS: .005 - .020
 SURFACE FINISH:
 GEOMETRIC TOLERANCING
 PER: ASME Y14.5 -2009
 MATERIAL: SEE DRAWING NOTES
 FINISH: SEE DRAWING NOTES
 DO NOT SCALE DRAWING

NAME	DATE
DRAWN MOB	01/03/23
CHECKED RB	01/03/23
COMMENTS:	

PROPRIETARY AND CONFIDENTIAL
 THE INFORMATION CONTAINED IN THIS DRAWING IS THE SOLE PROPERTY OF SUPPLYNET, INC. ANY REPRODUCTION IN PART OR AS A WHOLE WITHOUT THE WRITTEN PERMISSION OF SUPPLYNET INC. IS PROHIBITED.

CAGE CODE: 1HJX9

REF. NUMBER: SN0961

SupplyNet 706 EXECUTIVE BLVD
SUITE B
VALLEY COTTAGE, NY 10989

TITLE: **DAGR-DAGR, PLGR CABLE**
(NSN: 5995-01-521-2713)

SIZE	DWG. NO.	REV
B	SN-987-5011-001	A

SCALE: NA WEIGHT: SHEET 1 OF 1