

REVISIONS			
REV.	DESCRIPTION	DATE	ENG
A	INITIAL RELEASE	9/7/15	LS
B	DIAMETER ADJUSTED	9/12/23	CWA

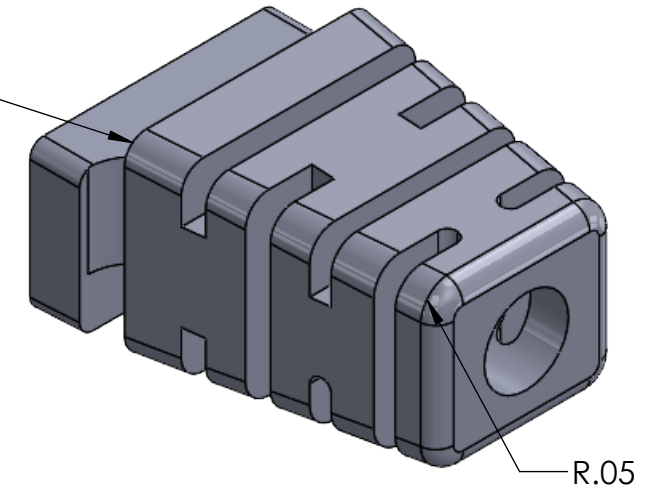

MATERIAL: PVC

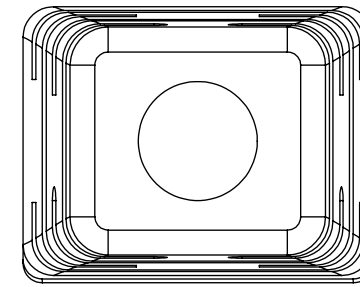
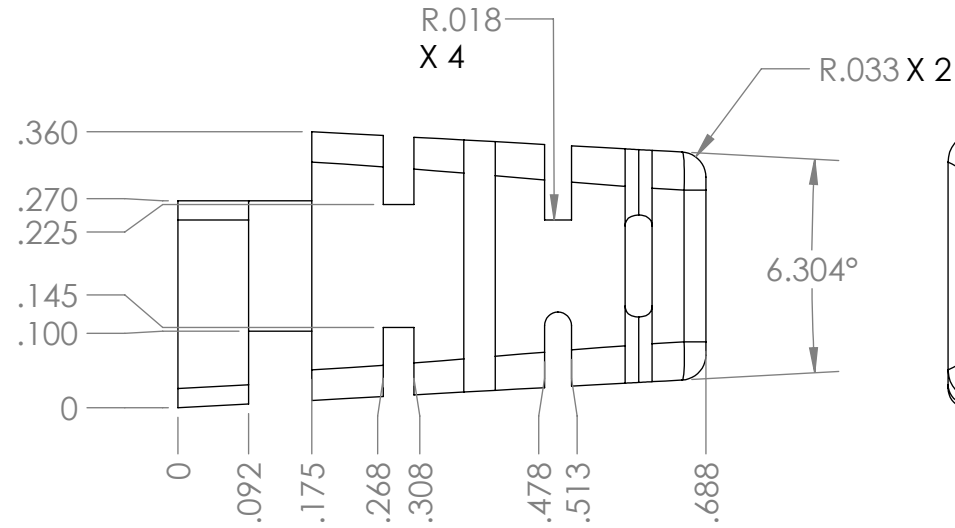
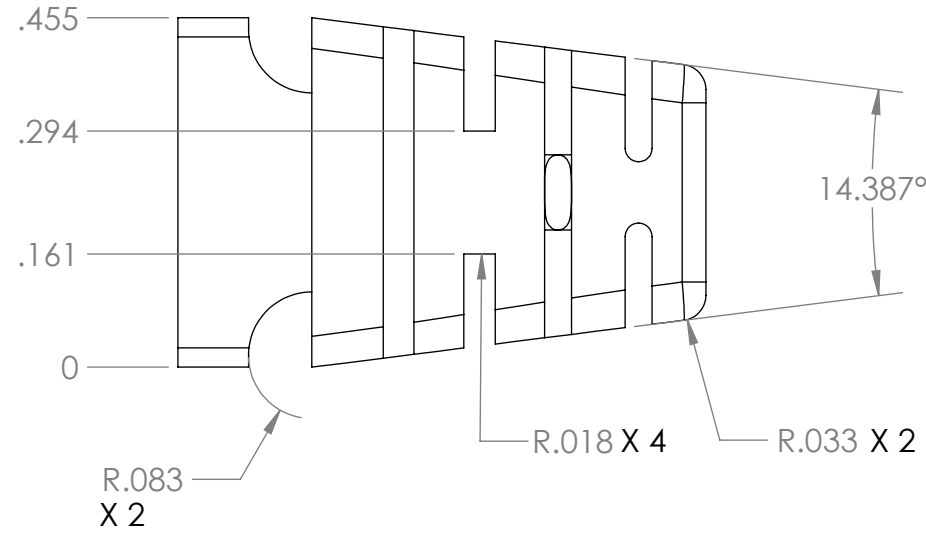
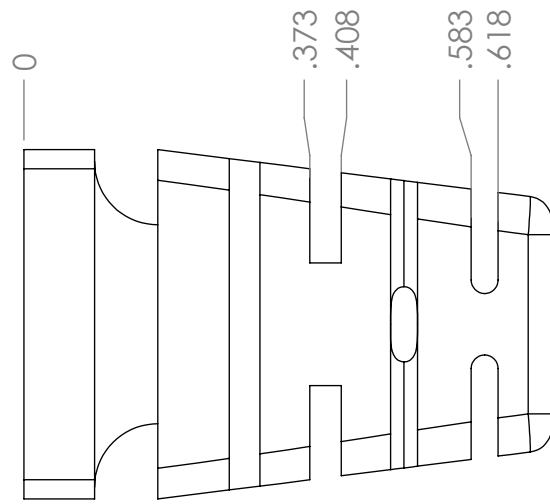

UNLESS OTHERWISE SPECIFIED:
 DIMENSIONS ARE IN: INCHES
 TOLERANCES: .XX: ± 0.03
 .XXX: ± 0.005
 ANGULAR: .X°: 1°
 .XX°: 0.5°
 BREAK EDGES: .005 - .020
 FILLETS: .005 - .020
 SURFACE FINISH:
 GEOMETRIC TOLERANCING
 PER: ASME Y14.5 -2009
 MATERIAL: SEE DRAWING NOTES
 FINISH: SEE DRAWING NOTES
 DO NOT SCALE DRAWING

	NAME	DATE
DRAWN	LS	DATE
CHECKED	RB	DATE
COMMENTS:		
PROPRIETARY AND CONFIDENTIAL		
THE INFORMATION CONTAINED IN THIS DRAWING IS THE SOLE PROPERTY OF SUPPLYNET, INC. ANY REPRODUCTION IN PART OR AS A WHOLE WITHOUT THE WRITTEN PERMISSION OF SUPPLYNET INC. IS PROHIBITED.		
CAGE CODE: 1HJX9		

REF. NUMBER: SN0479	
TITLE: STRAIN RELIEF, 0.15" DIA	
SIZE B	DWG. NO. FE-502-16B
REV B	
SCALE: NA	WEIGHT:
SHEET 1 OF 1	