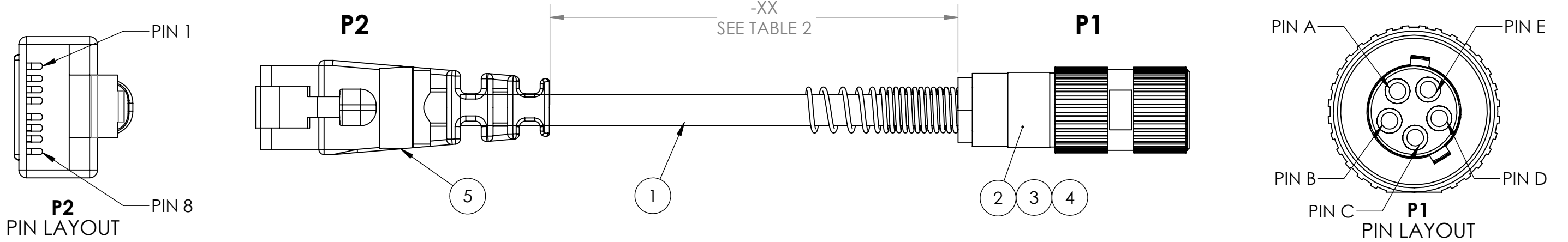
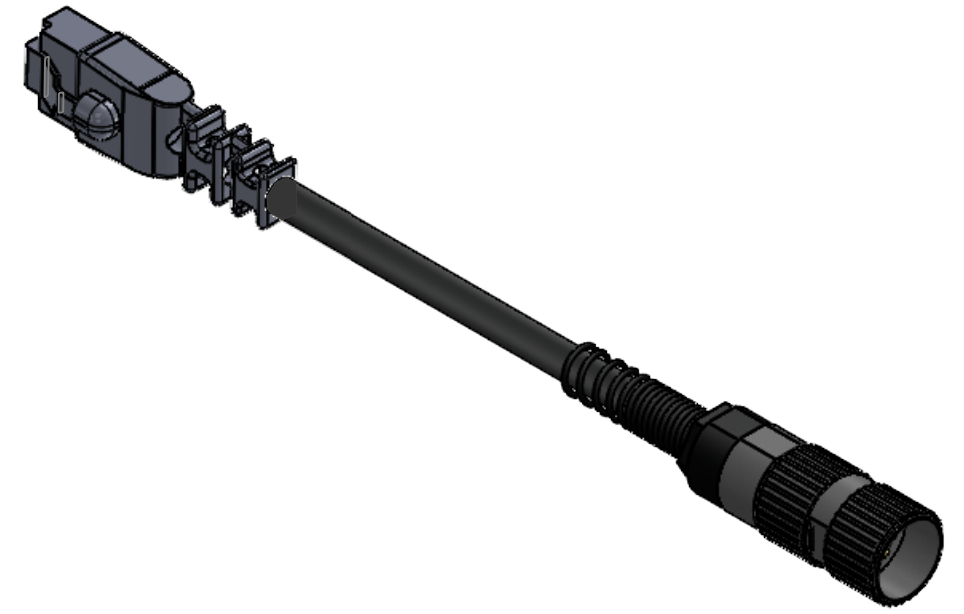

TABLE 2: WIRE LENGTH LIST		
-XX	LENGTH IN FEET	TOLERANCE
-01	1	+1.0", -0.0"
-03	3	+2.0", -0.0"
-06	6	+4.0", -0.0"
-12	12	+6.0", -0.0"
-15	15	+6.0", -0.0"
-16	16	+6.0", -0.0"
-20	20	+6.0", -0.0"
-25	25	+6.0", -0.0"
-30	30	+18.0", -0.0"

REVISIONS			
REV.	DESCRIPTION	DATE	APPROVED
F	UPDATED PART NUMBER ON RESISTORS BOM #5, #6	8/26/20	TC
G	Updated DWG format, Updated BOM, Updated Notes	6/9/23	DR
H	ADDED HOODED RJ45	11/30/23	CWA



- NOTES:
1. WIRING SHALL BE DONE IN ACCORDANCE WITH TABLE 1 WIRE RUN LIST.
  2. PACKAGING: EACH COMPLETED ASSEMBLY SHALL BE PLACED INTO A ZIP-POLY BAG AND MARKED PER SN-STD-LBL.
  2. SOLDERING: IAW IPC-J-STD-001 CLASS 2 AS APPLICABLE
  3. ASSEMBLY TO BE 100% TESTED FOR SHORTS, CONTINUITY, AND JACKET RESISTANCE (250V @ 100MOHM MIN.)
  4. MANUFACTURE AND INSPECT IAW IPC/WHMA A-620 CLASS 2.

UNLESS OTHERWISE SPECIFIED:  
 DIMENSIONS ARE IN: INCHES  
 TOLERANCES: .XX: ± 0.03  
 .XXX: ± 0.005  
 ANGULAR: .X°: 1°  
 .XX°: 0.5°  
 BREAK EDGES: .005 - .020  
 FILLETS: .005 - .020  
 SUFACE FINISH:  
 GEOMETRIC TOLERANCING  
 PER: ASME Y14.5 -2009  
 MATERIAL: SEE DRAWING NOTES  
 FINISH: SEE DRAWING NOTES  
 DO NOT SCALE DRAWING

	NAME	DATE
DRAWN	TC	10/21/15
CHECKED	RJB	10/21/15
COMMENTS:		

REF. NUMBER: SN0382

**SupplyNet** DESIGN ENGINEERING MANUFACTURING

TITLE: **U-229/U TO RJ45 (M) WAV CABLE**

SIZE	DWG. NO.	REV
<b>B</b>	<b>SN-1045-XX</b>	<b>H</b>

CAGE CODE: 1HJX9

SCALE: NA WEIGHT: SHEET 1 OF 1