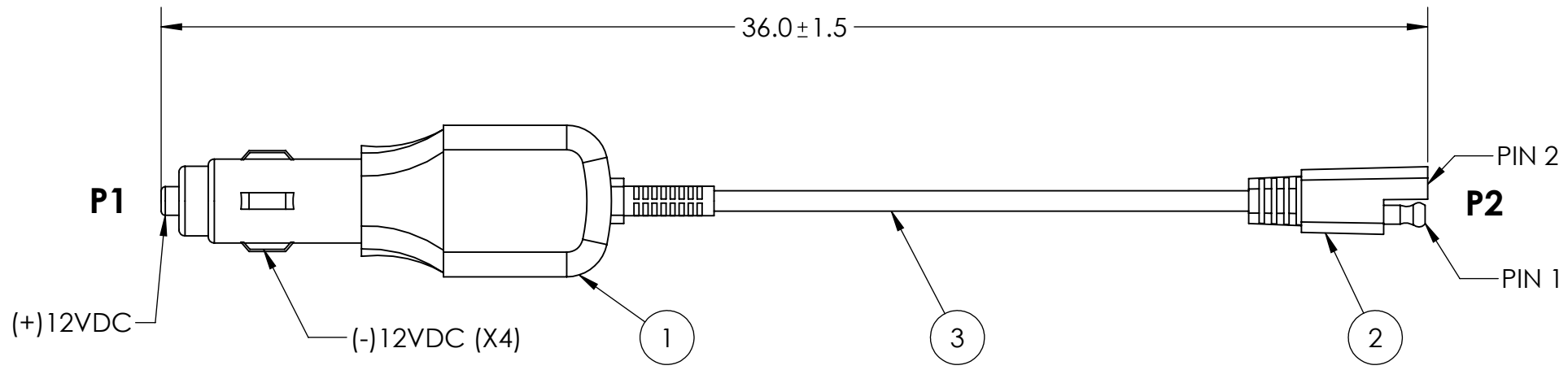
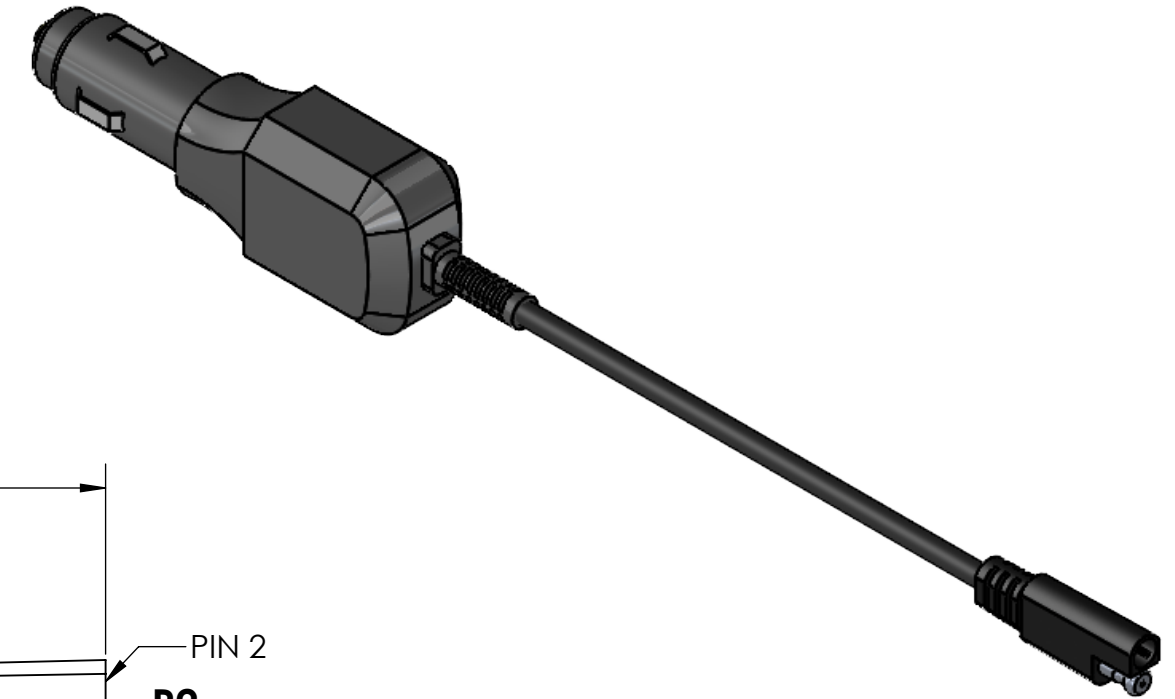
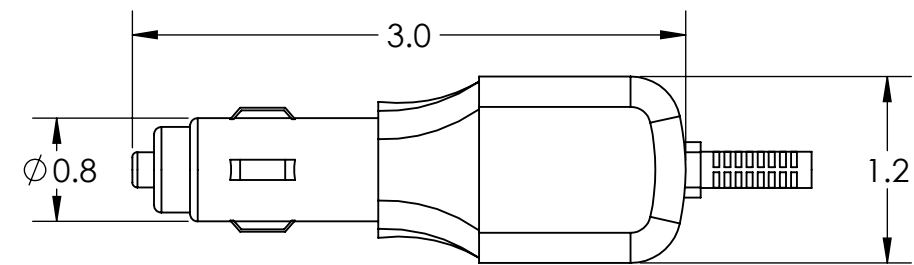

TABLE 1: WIRE RUN LIST		
P1	WIRE COLOR	P2
(+)12VDC	RED	2
(-)12VDC	BLACK	1

REVISIONS			
REV.	DESCRIPTION	DATE	ENG
2	CHANGED ITEM#3 PN	3/22/2021	MOB



BILL OF MATERIALS			
ITEM NO.	PART NO.	QTY	NAME/DESCRIPTION
1	A13-78	1	CIG ADAPTER MALE, 12VDC, 15A
2	TBD	1	SAE CONNECTOR
3	182C-V02B	AR	CABLE, 2C, 18 AWG, OD: 5mm

- NOTES:
- WIRE FUNCTION: SEE TABLE 1 WIRE RUN LIST.
 - CABLE LENGTH: 36.0 IN ± 1.5 IN.
 - ASSEMBLY TO 100% TESTED FOR CONTINUITY, SHORTS, AND JACKET RESISTANCE.
 - SOLDERING: IAW IPC-J-STD-001 CLASS II AS APPLICABLE.
 - IDENTIFICATION: BAG AND IDENTIFY ON PACKAGING THE FOLLOWING INFORMATION FOR EACH PART DELIVERED. PART MARKING ON THE WIRE IS PROHIBITED.
PN: SN-330-SAE REV. X (REV. "X" AS PER PO)
CAGE CODE: 1HJX9
MFD: MM/YY
 - MANUFACTURE AND INSPECT IAW IPC/WHMA A-620 CLASS 2.

UNLESS OTHERWISE SPECIFIED:	NAME	DATE
DIMENSIONS ARE IN: INCHES	DRAWN	MOB 3/22/2021
TOLERANCES: .XX: ± 0.03	CHECKED	RB 3/22/2021
.XXX: ± 0.005	COMMENTS:	
ANGULAR: .X°: 1°	PROPRIETARY AND CONFIDENTIAL	
.XX°: 0.5°	THE INFORMATION CONTAINED IN THIS DRAWING IS THE SOLE PROPERTY OF SUPPLYNET, INC. ANY REPRODUCTION IN PART OR AS A WHOLE WITHOUT THE WRITTEN PERMISSION OF SUPPLYNET INC. IS PROHIBITED.	
BREAK EDGES: .005 - .020	CAGE CODE: 1HJX9	
FILLET: .005 - .020	DO NOT SCALE DRAWING	
SURFACE FINISH:		
GEOMETRIC TOLERANCING PER: ASME Y14.5 -2009		
MATERIAL: SEE DRAWING NOTES		
FINISH: SEE DRAWING NOTES		

REF. NUMBER: SN0799

SupplyNet 706 EXECUTIVE BLVD.
SUITE B
VALLEY COTTAGE, NY 10989

TITLE: 12VDC CIG ADAPTER TO SAE CONNECTOR

SIZE B	DWG. NO. SN-330-SAE	REV 2
SCALE: NA	WEIGHT:	SHEET 1 OF 1